

SCHOTT ASI[®] Glass

Modular Sizes

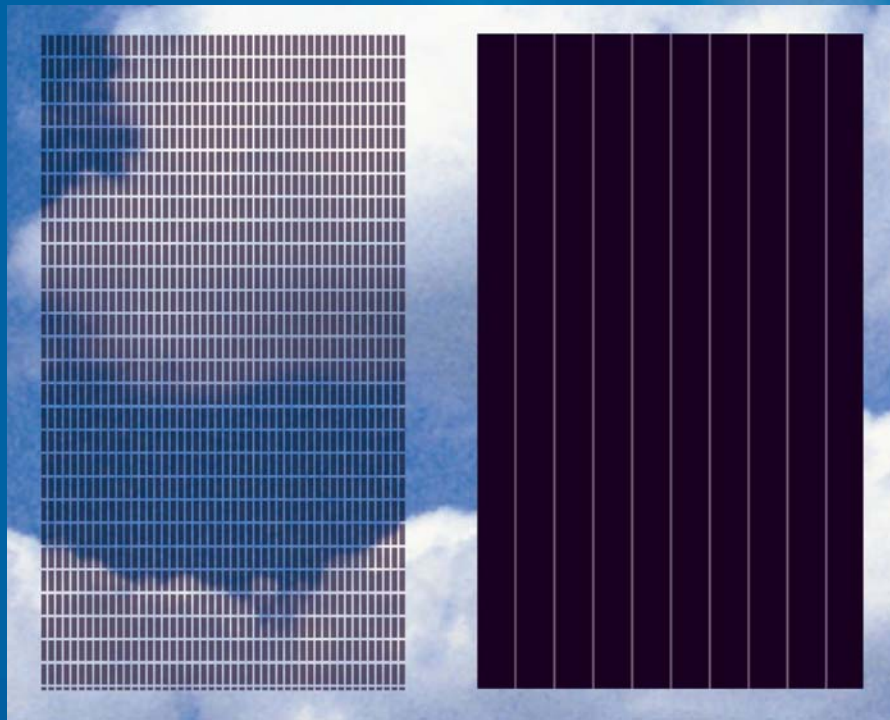

SCHOTT
glass made of ideas

SCHOTT ASI® Glass – Modular Sizes



- Solar electricity
- Light management
- Effective shading
- Glare protection
- Thermal management
- Innovative architecture
- Comfort
- Cost savings by combining and integrating several functions

The frameless glass laminates and double glazed elements are designed to be compatible with most conventional glazing systems for facades and skylights.

ASI® Glass elements are designed on the basis of SCHOTT Solar's ASI® thin-film technology as silicon tandem cells on glass superstrate. ASI® Glass elements demonstrably produce maximum energy yields.

Whether a façade or a roof, today's building envelope has to fulfill multiple purposes. Alongside its conventional roles of providing privacy and protection from rain and noise, additional factors are becoming increasingly important, such as thermal insulation and shading. All of these tasks have to be performed by the shell of a building. Today, building integrated photovoltaic systems are able to provide all of these functions plus solar electricity.



Laminates

Large area laminates are realized using up to 4 sub-modules forming a uniform area. The laminates given on the following pages are sorted according to the number of sub-modules being used.



SCHOTT ASI® Glass Laminates

Applications with semi-transparent laminates

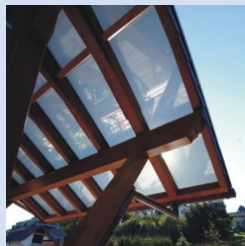
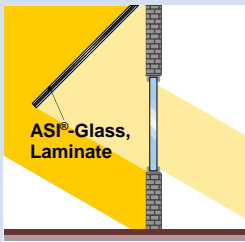

The use of semi-transparent laminates as sun shading lamellas offers effective shading while the semi-transparent modules allow you to see through to the surroundings or the sky.

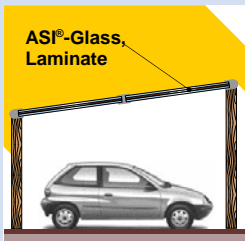

For carports or train stations, glazed roofs without a thermal insulation function are typical applications for semi-transparent laminates. It is possible to combine non-transparent ASI® OPAK areas with semi-transparent ASI® THRU areas. Additionally, clear glass elements can be integrated. This allows engineering the light falling through the glazed area for your specific project.

Application with non-transparent (opaque) laminates

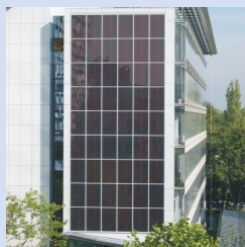
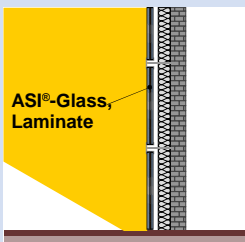

The non-transparent (ASI® OPAK) laminates can be used for rain screen cladding as well as for façades using transom and mullion systems.

Module design

All laminates come with two cable outlets on the rear face. The distance of the cable outlet to the laminate edge is defined by the active area of the module. The drawing at the right hand side shows the actual dimensions for the laminates shown within this data sheet.

Please note, the framing system needs to allow a sufficient distance between the cable outlet housing and the actual framework. Any mechanical load on the cable outlet housings must be avoided.

All modules are delivered with Multi-Contact connectors. Please note the geometry of the connectors when planning the cable guidance within your framework.

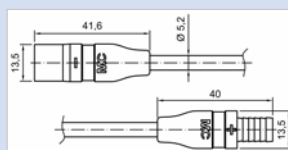

Multi-Contact connectors

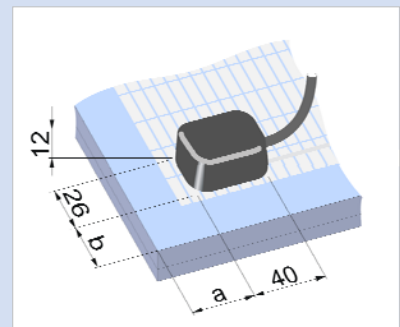

Cable outlet of a SCHOTT laminate
a = approx. 25mm
b = approx. 25mm

SCHOTT ASI® Glass – Double glazing

Double glazed units based on the ASI® THRU technology are always used when a thermal insulation, shading and of course electricity generation is required. The construction of the double glazed units offer the same thermal insulation compared with conventional double glazed units. As standard, the elements are offered with a U-Value of 1.1 W/m²K. For even higher requirements, please contact your local sales representative.

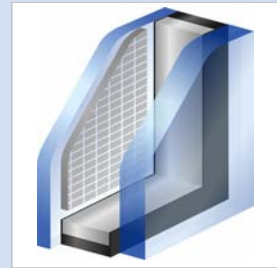

SCHOTT ASI® Glass, double glazing

Applications with double glazing



SCHOTT ASI® glass double glazing used in overhead application

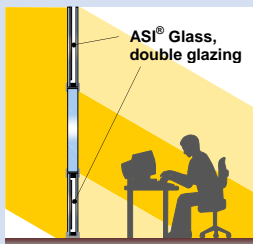

SCHOTT ASI® glass double glazing used in façade applications

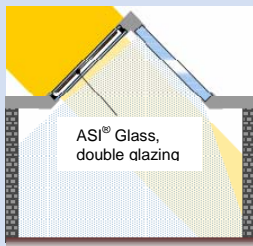

SCHOTT ASI® glass double glazing used in saw tooth roofs

Module design

All SCHOTT ASI® glass double glazing units are built with cable outlets exiting from the edge. These are designed to fit into the majority of transom and mullion systems available. The details are shown in the drawing on the right hand side. Please note, the cable outlets must not be used as setting blocks when installing the elements.

All modules are delivered with Multi-Contact connectors. Please note the geometry of the connectors when planning the cable guidance within your framework.

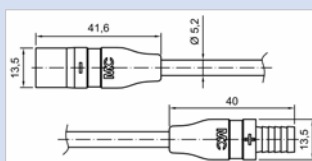

Multi-Contact connectors

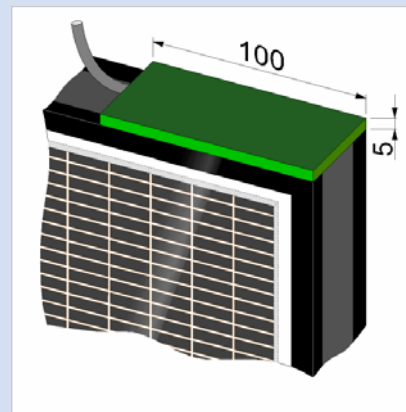

Cable outlet of a SCHOTT ASI® double glazing unit

SCHOTT ASI® Glass elements with 1 sub-module

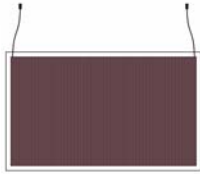
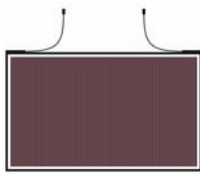
Version:	Laminate	Double glazing
		

Type:	ASI® THRU-1-L	ASI® THRU-1-IO
-------	---------------	----------------

Mechanical construction:

Front glass (low iron)	6 mm HSG	6 mm HSG
Interlayer	1.1 mm PVB	0.8 mm PVB
ASI® Glass (1x)	ASI® THRU	ASI® THRU
Interlayer	1.1 mm PVB	/
Cavity	/	18 mm / 20 mm
Back glass	6 mm HSG	8 mm LSG
Cable outlet	rear side	lateral
Cable type/diameter (+ and -)	Double isolated, black / 4.0 mm ²	
Outer diameter / cable length	Ø 6.0 mm / 1 m	
Connector (male / female)	Multi-Contact PV-KBT3 / PV-KST3	

Dimensions/Weight*:

Glass size	1122 mm x 690 mm	1122 mm x 696 mm
Active area	1072 mm x 640 mm	1072 mm x 640 mm
Total glass thickness	16 mm	34 mm
Total weight	29 kg	33 kg

Physical data*:**

U _g - Value (DIN EN 673)	~5 W/m ² K	1.1 W/m ² K
g-Value active area	27 %	10 %
Light transmission (active area)	10 %	10 %

Electrical Data:

Initial nominal power P _{mpp}	48 W _p	48 W _p
Nominal power P _{mpp} **	39 W _p	39 W _p
Current at nominal power I _{mpp} **	0.47 A	0.47 A
Short-circuit current I _{sc} **	0.55 A	0.55 A
Voltage at nominal power U _{mpp} **	83 V	83 V
Open-circuit voltage U _{oc} **	111 V	111 V
Maximum system voltage	600 V	600 V

SCHOTT ASI® Glass with 2 sub-modules

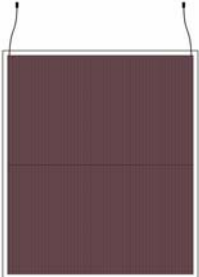
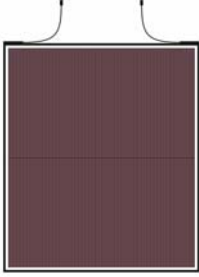
Version:	Laminate	Double glazing
		

Type:	ASI® THRU-2-L	ASI® THRU-2-IO
-------	---------------	----------------

Mechanical construction:



Front glass (low iron)	6 mm HSG	6 mm HSG
Interlayer	1.1 mm PVB	0.8 mm PVB
ASI® Glass (2x)	ASI® THRU	ASI® THRU
Interlayer	1.1 mm PVB	/
Cavity	/	18 mm / 20 mm
Back glass	6 mm HSG	8 mm LSG
Cable outlet	Rear side	lateral
Cable type/diameter (+ and -)	Double isolated, black / 4.0 mm ²	
Outer diameter / cable length	Ø 6.0 mm / 1 m	
Connector (male / female)	Multi-Contact PV-KBT3 / PV-KST3	

Dimensions/Weight*:



Glass size	1122 mm x 1331 mm	1122 mm x 1337 mm
Active area	1072 mm x 1280 mm	1072 mm x 1280 mm
Total glass thickness	16 mm	34 mm
Total weight	58 kg	65 kg

Physical Data*:**



U _g -Value (DIN EN 673)	~5 W/m ² K	1.1 W/m ² K
g-Value (active area)	27 %	10 %
Light transmission (active area)	10 %	10 %

Electrical Data:



Initial nominal power P _{mpp}	95 W _p	95 W _p
Nominal power P _{mpp} **	78 W _p	78 W _p
Current at nominal power I _{mpp} **	0.94 A	0.94 A
Short-circuit current I _{sc} **	1.11 A	1.11 A
Voltage at nominal power U _{mpp} **	83 V	83 V
Open-circuit voltage U _{oc} **	111 V	111 V
Maximum system voltage	600 V	600 V

SCHOTT ASI® Glass with 3 sub-modules

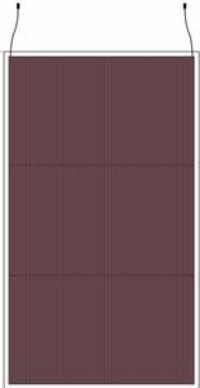
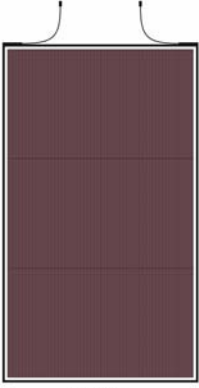
Version:	Laminate	Double glazing
		

Type:	ASI® THRU-3-L	ASI® THRU-3-IO
-------	---------------	----------------

Mechanical construction



Front glass (low iron)	6 mm HSG	6 mm HSG
Interlayer	1.1 mm PVB	0.8 mm PVB
ASI® Glass (3x)	ASI® THRU	ASI® THRU
Interlayer	1.1 mm PVB	/
Cavity	/	18 mm / 20 mm
Back glass	6 mm HSG	8 mm LSG
Cable outlet	Rear side	lateral
Cable type/diameter (+ and -)	Double isolated, black / 4.0 mm ²	
Outer diameter / Cable length	Ø 6.0 mm / 1 m	
Connector (male / female)	Multi-Contact PV-KBT3 / PV-KST3	

Dimensions/Weight*:



Glass size	1122 mm x 1972 mm	1122 mm x 1978 mm
Active area	1072 mm x 1920 mm	1072 mm x 1920 mm
Total glass thickness	16 mm	34 mm
Total weight	86 kg	95 kg

Physical Data***:



U-Value (DIN EN 673)	~5 W/m ² K	1.1 W/m ²
g-Value (active area)	27 %	10 %
Light transmission (active area)	10 %	10 %

Electrical Data:



Initial nominal power P_{mpp}	143 W _p	143 W _p
Nominal power P_{mpp}^{**}	117 W _p	117 W _p
Current at nominal power I_{mpp}^{**}	1.41 A	1.41 A
Short-circuit current I_{sc}^{**}	1.66 A	1.66 A
Voltage at nominal power U_{mpp}^{**}	83 V	83 V
Open-circuit voltage U_{oc}^{**}	111 V	111 V
Maximum system voltage	600 V	600 V

SCHOTT ASI® Glass with 4 sub-modules

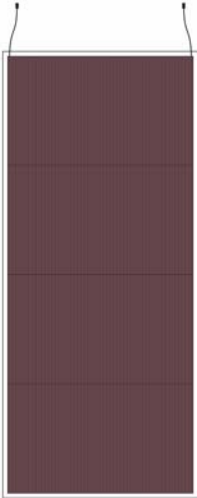
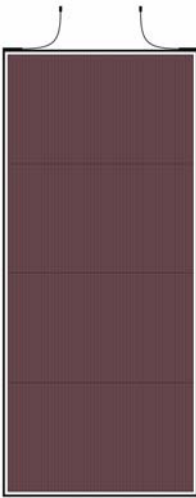
Version:	Laminate	Double glazing
		

Type:	ASI® THRU-4-L	ASI® THRU-4-IO
-------	---------------	----------------



Mechanical construction:

Front glass (low iron)	6 mm HSG	6 mm HSG
Interlayer	1.1 mm PVB	0.8 mm PVB
ASI® Glass (4x)	ASI® THRU	ASI® THRU
Interlayer	1.1 mm PVB	/
Cavity	/	18 mm / 20 mm
Back glass	6 mm HSG	8 mm LSG
Cable outlet	Rear side	lateral
Cable type/Diameter (+ and -)	Double isolated, black / 4.0mm ²	
Outer diameter / Cable length	Ø 6.0 mm / 1 m	
Connector (male / female)	Multi-Contact PV-KBT3 / PV-KST3	



Dimensions/Weight*:

Glass size	1122 mm x 2613 mm	1122 mm x 2619 mm
Active area	1072 mm x 2560 mm	1072 mm x 2560 mm
Total glass thickness	16 mm	34 mm
Total weight	114 kg	126 kg



Physical Data*:**

U _g -Value (DIN EN 673)	~5 W/m ² K	1.1 W/m ² K
g-Value (active area)	27 %	10 %
Light transmission (active area)	10 %	10 %



Electrical Data:

Initial nominal power P _{mpp}	190 W _p	190 W _p
Nominal power P _{mpp} **	156 W _p	156 W _p
Current at nominal power I _{mpp} **	1.87 A	1.87 A
Short-circuit current I _{sc} **	2.22 A	2.22 A
Voltage at nominal power U _{mpp} **	83 V	83 V
Open-circuit voltage U _{oc} **	111 V	111 V
Maximum system voltage	600 V	600 V

Notes on given technical data

- * The tolerances of the outer glass dimensions are ±3 mm.
- ** These data represent stabilised electrical module performance at standard test conditions (STC -1000 W/m²; AM 1.5; 25°C cell temperature). The nominal power may be initially approx. 18 % higher than the quoted stabilised power data. This power bonus has to be considered when designing the system. All given electrical data are subject to a production tolerance of ± 10 %.
- *** The given g-Values and U-values are approximate data.

Cell temperature coefficients

Referred to nominal power	$T_k (P_n)$	- 0.2 % / K
Referred to open-circuit voltage	$T_k (U_{oc})$	- 0.31 % / K
Referred to short-circuit current	$T_k (I_{sc})$	+ 0.08 % / K

Notes on system design

Negative potentials:	Any negative potential between SCHOTT ASI® glass modules and earth (ground potential) must be avoided for installations with a system voltage exceeding 100V. This requirement has to be ensured by an adequate system design. Please contact your inverter supplier for details regarding this requirement..
Shading:	Solar modules based on the SCHOTT ASI® technology are very shading tolerant. However, shades covering fully one or more cells have to be avoided.
Reverse current:	The maximum reverse current must not exceed two times the short circuit current (2 x I _{sc}). It is recommended to provide a fuse for each string (serial interconnection of single PV-elements). The recommended fuse rating for string fuse is two times the short-circuit current (2 x I _{sc}).
General:	Never exceed the given maximum system voltage. Under normal conditions, a photovoltaic module may experience conditions that produce more current and/or voltage than reported at Standard Test Conditions.

Product nomenclature

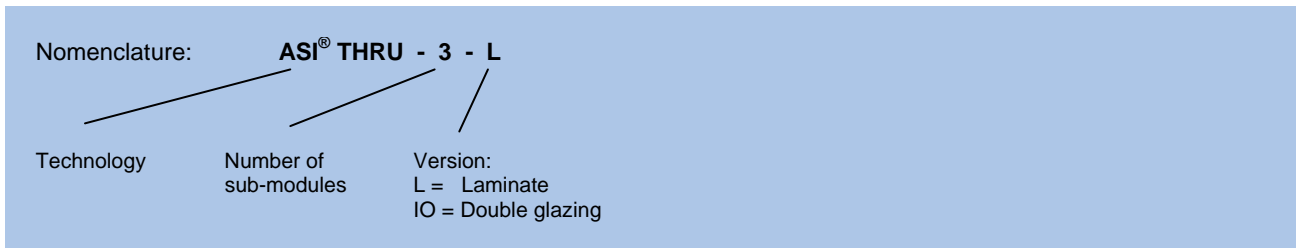

Appearance of the semiconductor

Thin-film silicon modules may exhibit slight variations in colour, both across any given module and from module to module. These non-uniformities are caused by optical interference effects within the semiconductor layers, and are thus inherent to the manufacturing process. Most importantly, however, the perceived colour differences have no influence whatsoever on the electrical performance of the modules and their service life, and, therefore, present no reason for rejection.

Quality of glass and lamination

Glass

- HSG: Heat Strengthened Glass (semi toughened glass) according to DIN EN 1863-1
- LSG: Laminated Safety Glass (float glass / PVB foil /float glass) according to DIN EN 12543-1

Lamination foil:

For all given laminates and double glazing elements only PVB (Polyvinylbutyral) interlayer will be used with the following mechanical parameters:

- Tensile Strength > 20 N/mm²
- Breaking Elongation > 250 %

The glass edges are not polished. Due to the production process, isolated and sporadic small bubbles in the laminate in the rim area and main areas of the glass panes may appear and are not considered to be defects.

The choice of glass thickness and quality, such as float glass, heat strengthened glass or fully hardened glass is not the responsibility of SCHOTT. All glazing has to be built according to relevant building codes, national standards and best practice for glazed structures. The actual specifications for glass configuration has to be determined by the architect or buyer based upon local building codes. On request the inner glass of all double glazing units can be offered as safety glass laminate based on heat strengthened glass.

Qualifications:

Qualification: CE conformity

The right is reserved to make technical modifications.

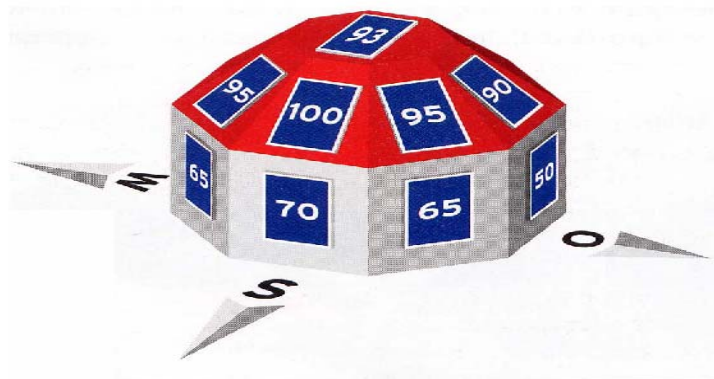

High energy yields are generated by arranging for the system to face south at a horizontal angle of 30° (100). The yield values will be somewhat lower if the direction deviates from this.

Architecture + Design
SCHOTT North America, Inc.
555 Taxter Road
Elmsford, NY 10523
Phone: 914.831.2241
Fax: 914.831.2346
architecture@us.schott.com
www.us.schott.com/architecture

SCHOTT
glass made of ideas