

# Newsletter

SCHOTT Advanced Optics

**VOL III NO. II, June 2008**

## **TECHNICAL INFORMATION & PRODUCT NEWS**

High refractive index glass LASF35 ( $n_d = 2.02204$ ;  $v_d = 29.06$ ) is now available from continuous melt with improved internal transmittance

SCHOTT sets new standards in quality insurance

## **VOICE OF THE CUSTOMER & INDUSTRY TRENDS**

SCHOTT Hosts Customer Event at Photonics West 2008

“Building a Diverse Product Line”  
by Dr. Johannes Hain, Exec. VP of Business Unit Advanced Materials, SCHOTT AG

“TMT: Progress and Approaches”  
by Dr. Jerry Nelson, Professor of Astronomy for the Center for Adaptive Optics, University of California

“Optimizing your design for as-built molded asphere production” by John Tamkin, Director of Imaging Engineering Services, Optical Research Associates

“Global Trends in Optical Manufacturing” by Stuart Schoenmann, CEO, CVI Melles Griot

Advanced Optics awarded “Supplier of the Year” by UVEX Group

## **REGIONAL & CLOSE UP**

SwissCube - the first entirely Swiss-made student satellite

SCHOTT Advanced Optics Establishes Branding Partnership

LASER China - where partnerships are strengthened

## **UPCOMING SCHOTT EVENTS**

Page

## **High refractive index glass LASF35 ( $n_d = 2.02204$ ; $v_d = 29.06$ ) is now available from continuous melt with improved internal transmittance**

SCHOTT has improved the product range of high refractive index glass types by transferring LASF35 ( $n_d = 2.02204$ ;  $v_d = 29.06$ ) into continuous production.

Continuous production has been specially adapted to the glass system to achieve superb internal transmittance in the blue area (internal transmittance 63% at 400 nm, for 10 mm thickness; color code: 45/37).

SCHOTT is thereby able to offer a glass type with an  $n_d$  of 2.0 with significant higher transmittance in the blue than what is offered by the competitors. If very high refractive index and high transmittance in the blue are required, LASF35 would be the glass of choice. LASF35 is used for optical systems where high refractive power is required such as endoscopy, micro-optics, defense and microscopy. LASF35 is ROHS compliant.

### **Homepage Relunched**

*The pre-announced relaunch of our homepage has been realized.*

*The German and English pages are now available*

*The Relaunch of the Chinese and Japanese pages will follow soon!*

## SCHOTT sets new standards in quality insurance

In the application center ACA in Suzhou, China, a new metrology tool 'spectrometer type V-block' was installed recently. The equipment, developed by engineers of SCHOTT's Research and Development department headed by Laboratory Manager Dr. Axel Engel, works with a specialized metrology procedure which aligns certain procedures, mathematical corrections as well as selected evaluations which allow the precise definition of refractive indices and dispersion of optical glass.

"Thanks to the installation of the new tool 'spectrometer type V-block' we are now able to provide a reliable quality control of optical components here directly at ACA in Suzhou which offers an even better and faster service to our customers in joint projects here in China" says Dr. José Zimmer, Director of the Application Center Asia in Suzhou, China. With the highly precise definition of refractive index and dispersion value, SCHOTT is now able to verify and approve the optical characteristics and quality values of its optical materials much faster and more easily.

The robust and shock resistant tool can be used by people with less training without losing its accuracy. It is being used for

the evaluation of raw materials and components for optical high precision applications, such as high precise lenses or prisms for digital cameras or projectors. With the new metrology tool at the ACA, customers can now benefit even more from the proximity to the know-how of SCHOTT, who once again took an important step to optimize the co-operation with its partners and customers in Asia by offering increased and faster direct technical support in China.



*Kevin Chen, Application Engineer Optics in Suzhou working with the new metrology tool*

[BACK TO INDEX](#)

## SCHOTT Hosts Customer Event at Photonics West 2008

**“Building a Diverse Product Line” by Dr. Johannes Hain, Exec. VP of Business Unit Advanced Materials, SCHOTT AG**

For the third year in a row, SCHOTT hosted a customer event during Photonics West. At this event SCHOTT invites partners and customers and offers a platform for speakers representing the leading

companies and institutions of the industry. At this year’s luncheon approximately 50 guests had the opportunity to hear the following speakers:

Dr. Hain gave a short overview about how SCHOTT developed through the years and constantly extended its product portfolio to reflect the requirements of the industry. Today SCHOTT can be seen as the “One Stop Shop” offering products along the entire spectral range by introducing the IR grade material to the American market thereby unifying capabilities from developing glass, its production to the processing according to its customers requirement to a value added final processed optical component.



*Dr. Johannes Hain explaining the product portfolio of SCHOTT*

[BACK TO INDEX](#)

**“TMT: Progress and Approaches” by Dr. Jerry Nelson, Professor of Astronomy for the Center for Adaptive Optics, University of California**

Mr. Nelson gave an overview of the design and status of the Thirty Meter Telescope project, a project to build a ground-based 30 m diameter optical and infrared telescope. With adaptive optics, TMT will have unprecedented resolution and sensitivity for the study of faint and distant objects in the Universe. The project is in its late design phase and there are plans to begin construction in 2009 with science operations beginning in 2016. The project is a partnership between the University of California, Caltech, and Canada.



*Dr. Jerry Nelson, Professor of Astronomy for the Center for Adaptive Optics of the University of California explaining the upcoming TMT project*

[BACK TO INDEX](#)

**“Optimizing your design for as-built molded asphere production” by John Tamkin, Director of Imaging Engineering Services, Optical Research Associates**

Molded glass aspheres can provide significant cost benefit, but have unique manufacturing challenges. Tuning your design for as-built mold characteristics can improve performance and yield. In this talk, Tamkin described the usefulness of Zernike polynomials in optimizing and tolerancing molded aspheric designs. He showed an example of how a designer can take as-built Zernike terms and recompile the nominal design to achieve better production performance without increase in cost.



*John Tamkin, Director of Imaging Engineering Services at ORA addressing the aspheres topic*

[BACK TO INDEX](#)

**“Global Trends in Optical Manufacturing” by Stuart Schoenmann, CEO, CVI Melles Griot**

This presentation addressed the current optical manufacturing trends within the industry, with respect to the emerging global market for optical components and materials. It explained how the need for organic growth within CVI Laser Corporation was addressed by vertical integration domestically, and by international expansion through acquisition. The challenge of Chinese competition was one of the factors involved in this growth, but since CVI has always maintained a manufacturing presence in Korea, it became necessary to look at a European presence as well. Melles Griot had a strong brand and market presence in Europe, which led to its consideration as an acquisition target. In addition to the acquisition of the larger Melles Griot, CVI also acquired Quality Laser Optics and Coherent Technologies in the UK, bringing to the table capacity to process large optics as well as IR materials. These acquisitions brought the

unification of world-wide branding under the banner of CVI Melles Griot. Trends for consolidation both geographically and internationally provide a “tripod of strength” on key continents, and allow further product extensions and expansions as well as the leveraging of assets and resources into new markets.



*Stuart Schoenmann, CEO of CVI Melles Griot explaining how CVI is structured reflecting the trends of the market*

[BACK TO INDEX](#)

## Advanced Optics awarded "Supplier of the Year" by UVEX Group

Superior quality drives growth

In March the board of management of the UVEX group based in Fürth, Germany, presented Advanced Optics with the "UVEX Supplier of the Year 2007 - Technology" award for its long term cooperation with LASERVISION, a subsidiary of UVEX safety group. LASERVISION is one of the world's leading suppliers of high quality laser protection windows and eyewear.

"We have been cooperating closely since 1975," says Peter M. Bura, Managing Director of LASERVISION GmbH & Co. KG. "Over the many years, the laser market has developed strongly and so has our portfolio of suitable protection solutions. SCHOTT Advanced Optics has been supporting our success for more than three decades as a very reliable, flexible and innovative partner," he adds.

Optical glass filters are core components for laser protection windows and safety eyewear. When integrated into protective eyewear and window frames, special optical filters protect the laser engineer's vision.

As high power lasers are increasingly being used in industrial and medical applications, quality is becoming more important in vision protection. "All laser protection solutions produced by LASERVISION with SCHOTT

glass filter components meet the requirements of the European DIN EN 207, DIN EN 208 and DIN EN 60825, as well as the US ANSI standard," says Norbert Nuss, Key Account Manager for Advanced Optics at SCHOTT AG. "We are seeing an increase in demand for optical glass filters, due to greater safety awareness and stronger safety regulations. In addition, more and more high power lasers are now being used all around the world" Nuss explains.

Advanced Optics supplies shortpass filter glasses, such as KG 3 and KG 5, (especially for the 1064 nanometer wavelength of Nd:YAG-Lasers), as well as filters with longpass and bandpass characteristics often refined by using coatings or tempering processes.



*Gabriele Grau, Andreas Fiedler, Peter Bura and Frank Seuling (f.l.t.r. and right) representing the UVEX Group and Laservision GmbH & Co. KG as well as Dr. Thomas Kessler and Norbert Nuss from Advanced Optics, SCHOTT AG during the event in Fürth*

[BACK TO INDEX](#)

## SwissCube - the first entirely Swiss-made student satellite

SCHOTT is currently contributing to an exciting project that is being carried out in Switzerland: the SwissCube program. The primary objective of this project is to train students in space system engineering, prepare them to work in the space industry or related high technology fields, and to foster a very tight collaboration between Swiss research labs and the different partner institutions and industries.

Weighing only 1 kilogram, and measuring 10 centimeters on a side, the SwissCube will be the first pico-satellite entirely built by a consortium of Swiss schools composed of the Federal Polytechnic University in Lausanne (team leader), the University of Neuchâtel and four Swiss engineering schools. It is designed, built and tested by students with the support of the Swiss space industry. SCHOTT's contribution is a highly specialized coating on components that are used in the project.

The SwissCube mission aims at observing and taking measurements of the airglow phenomena. The airglow is a photoluminescence of the atmosphere occurring at approximately 100 km altitude. The scientific objective of SwissCube is to observe oxygen emission at 762 nm in order to characterize the airglow intensity as a function of the observation angle, the altitude, the latitude and the local time. The minimum science duration is 3

months, with an extended science mission of duration up to 1 year.

The motivation for these observations is to demonstrate the feasibility of using the airglow as a basis for development of a low cost Earth Sensor (such sensors will be used by subsequent satellites). A model of the airglow emissions as a function of intensity, latitude, longitude and time has been established and the objective of the science mission is to collect data that will validate the model.

Launch is planned for the beginning of 2009. SCHOTT is, as all other members of the team involved in the project, observing the progress of the program with keen interest.

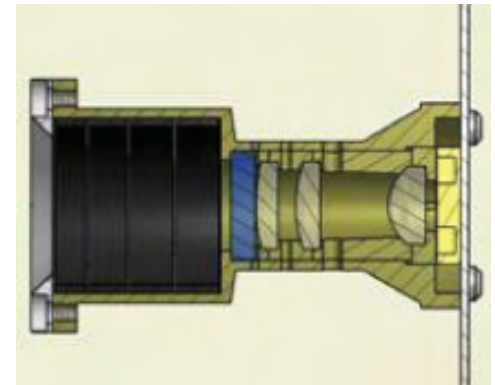

*The SwissCube Telescope that will take a picture of the airglow.*

[BACK TO INDEX](#)

## SCHOTT Advanced Optics Establishes Branding Partnership

On March 17, 2008, Suzhou Synta Optical Technology Co., Ltd. and SCHOTT AG signed a contract for a joint branding initiative. This is a key milestone to intensify the cooperation between both companies.

Synta, one of the largest Taiwanese manufacturers of Consumer Astronomical telescopes, is based in China. Well known brands, such as SkyWatcher, Celestron and ORION, are some of Synta's products that are mostly sold in NAFTA and European markets.

Synta has already been working together with SCHOTT. SCHOTT is the preferred material supplier, especially for its high end products and with the branding partnership with SCHOTT, Synta can emphasize its high quality standards. SCHOTT, on the other hand, will gain wider recognition among telescope users and strengthen global brand and product portfolio awareness. "We are proud that we could intensify our cooperation with Synta, a reliable and promising branding partner, through signing this contract. The agreement is a win-win situation for both parties," states Dr. Johannes Hain, Executive Vice President, Business Unit Advanced Materials.

Currently, this agreement covers the joint branding of 4 products, which will be co-branded with the logo - "contains SCHOTT optical glass". SCHOTT is also looking into new options to expand the scope of co-branded products and to intensify the cooperation of both companies, by offering additional value added solutions.

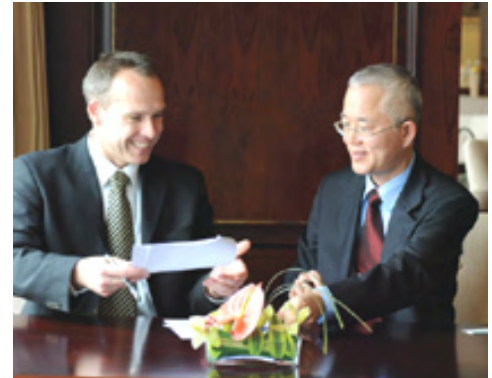

*Dr. Johannes Hain, Executive Vice President, Business Unit Advanced Materials, and David Shen, President Synta Optical Technology Co., Ltd, signing the contract.*



*The Telescope, SkyWatcher ED 120, one of the branded products from Synta*

[BACK TO INDEX](#)

## LASER China - where partnerships are strengthened

This year's "LASER - World of PHOTONICS" China took place for the third year in a row and was held from March 18-20, 2008 in Shanghai. This exhibition has been gaining in importance through the years and is now being considered as one of the most important information platforms for optical technologies in China. This year's attendance of the exhibition could set a new record: the number of visitors doubled in comparison to the previous year up to 18,428 and the exhibition space of the 200 exhibitors increased by approximately 30%, whereas approx. 130 exhibitors came from China and 71 from foreign countries with 42 coming out of Germany.

The strong German participation was mostly due to the special show "German World of Laser & Photonics", which incorporated new technologies and products of German companies. Dr. Johannes Hain, Executive Vice President of the Businesses Unit Advanced Material had the position as the president of this special show and represented not only the interests of SCHOTT but also of

all participating enterprises. "It is an investment in the very good partnership and co-operation between China and Germany in the field of optics and laser technology. The special show supports the development and establishment of contacts of German companies with Chinese partners, distributors and customers" explained Hain at the press conference taking place at the exhibition.

For SCHOTT, once again, this year's exhibition was an outstanding platform to maintain existing contacts, to build up new co-operations and to put emphasis on its commitment to the Chinese market. The high quality of contacts and the interest of the media showed that SCHOTT in China, as one of its key markets, has undertaken the right way.



*SCHOTT presenting a large ZERODUR® blank at LASER China*

[BACK TO INDEX](#)

## Upcoming SCHOTT Events

ICO-21 2008 Congress & OECC/ACOFT 2008 Conference – July 7 - 10, 2008,  
Sydney, Australia

Semicon West – July 15 - 17, 2008,  
San Francisco, CA, USA

SPIE's Optics & Photonics – August 10 - 14, 2008,  
San Diego, CA, USA

CIOE 2008 – September 6 - 9, 2008,  
Shenzhen, China

Salon Opto – September 30 - October 2, 2008,  
Paris, France

SCHOTT is also supporting Photonex UK, IFA Germany and Photokina  
Germany

[BACK TO INDEX](#)