



KL 2500 LCD

KL 2500 LCD

Twice the amount of light – ideal for special applications

The KL 2500 LCD is the performance leader in light sources from SCHOTT.

With its 250-Watt light reflector lamp, the KL 2500 LCD exceeds twice the amount of light given by the KL 1500 LCD. It produces many-fold the amount of light currently available from other 150-Watt devices.

Unparalleled performance of the KL 2500 LCD makes it the instrument of choice for all applications in microscopy which demand a higher light output. Where meeting macro-photography's shorter exposure requirements, light reserve for forensic and GFP fluorescence applications, the KL 2500 LCD is the right device.

- **Ease of use:** The KL 2500 LCD is supplied with a filter wheel, which accommodates up to five insert filters. Filter selection is as simple as a turn of the knob.
- **Electronic accessories,** such as remote control, RS-232 or tilt switch, can be connected to the front panel of the device enabling light source operation in difficult access areas.
- With the **modified light guide socket,** light guides up to 15-mm fiber bundle diameter can be used with optimum results. Design compatibility allows KL 1500 LCD light guides to also be used with the KL 2500 LCD.
- All other functions are identical to the KL 1500 LCD.
- **Approvals:**
The KL 2500 LCD has been approved and certified by VDE and UL (120-Volt version for U.S. and Canada) and carries the CE conformity label (230-Volt version).
- Manufactured in the EU.

KL 2500 LCD

Type designation		General data	
Dimensions (W x D x H)		(mm)/(inch)	Ca. 200 x 265 x 170/Ca. 7.9" x 10.4" x 6.7"
Weight		(kg)	Approx. 6.0
Cooling		Low-noise fan	
		Part-No.	Electrical data
Operating voltage	120 volt version	250 201	100 V ~ 50/60 Hz, 120 V ~ 60 Hz
	230 volt version	250 200	220 V ... 240 V ~ 50/60 Hz
Protection Class		II	
Lamp type		Halogen reflector lamp Type ELC	
Lamp voltage rating (V)		24	
Lamp power rating (W)		250	
Average lamp	level 4	(h)	1500
service life	level 5	(h)	150
Illumination data			
Light flux		(lm)	1300
Light control		Electrical and mechanical	
Active light guide diam.		(mm)/(inch)	Max. 15/Max. 0.59"
Certification marks			
120 volt version		CSA (C/US)	
230 volt version		CE, CSA	

Product improvements may result in specification or feature changes without notice.

KL 2500 LCD

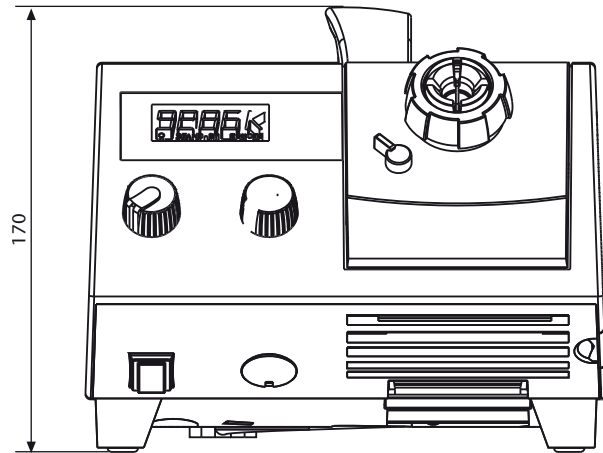
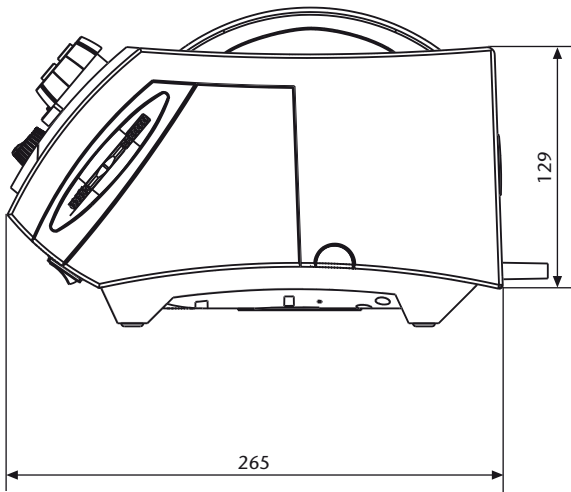

9 PIN connector for remote control
or electronic accessoires

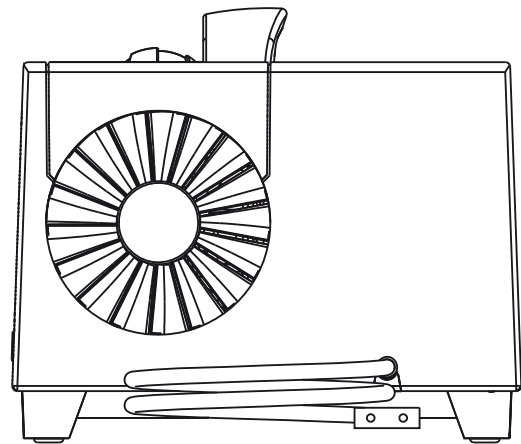

Lighting and Imaging
SCHOTT North America, Inc.
122 Charlton Street
Southbridge, MA 01550-1960
USA

Phone: +1 508/765-9744
Fax: +1 508/764-6273
lightingimaging@us.schott.com
www.us.schott.com/lightingimaging

SCHOTT
glass made of ideas

For your local sales contact please visit
www.us.schott.com/lightingimaging